

# OMNI 1

# USER MANUAL

**ComMarker OMNI 1 UV Laser Engraver**

Machine Assembly Guide

Operation Tutorial



# Contents

01 Safety Warning.....	2
02 Product Structure.....	3
03 List of Items.....	4
04 Parameters.....	5
05 Assembly of Machine.....	6
06 Turn On the laser.....	7
07 Operation Instructions.....	8 -13
08 Lightburn Operation Tutorial.....	14-16
09 FAQ.....	17-18
10 Maintenance.....	19

# Safety Warning



Before using the laser engraving machine, please read this safety guide carefully.

- **Do not leave the device unattended while in operation.** Ensure it is functioning properly at all times.
- Check the machine for damage every time before you use it. Do not operate it in any way when any damage or defect is found.
- Inspect the machine for damage before each use. Do not operate if any damage or defects are detected. Ensure the workspace is clean and level.
- Do not disassemble or alter the machine's structure without authorization. Do not modify or do compile its operating system.
- Keep the interior of the machine clean. Accumulated residues and debris from cutting and engraving can be hazardous and may cause a fire. Regularly clean the work area to remove chippings and residues.

## 1 Laser Safety

- The machine uses Class IV lasers, which are extremely powerful and can cause eye injuries or burn the skin. It is recommended to wear laser safety goggles when operating the laser engraver.
- Avoid direct exposure of your skin to Class IV laser beams, especially at close range.
- Teenagers must be supervised by a parent or guardian while using the machine.
- Do not touch the laser engraving beam while it is active.

## 2 Material Safety

- Do not engrave materials with unknown properties.
- Recommended materials for engraving include:
  - Metals: stainless steel, aluminium, bronze, brass, alloys, etc.
  - Plastics: PP, PE, ABS, etc.
  - Non-metals: wood, leather, paperboard, etc.

## 3 Use Safety

- Do not point the laser at people, animals, or any combustible objects, whether the device is active or not.
- Operate this laser engraving device in compliance with all applicable local and national laws and regulations.
- Use the device strictly in accordance with this instruction manual and the engraving software manual.
- Ensure that any untrained personnel near the device are informed of its dangers before operation.

## 4 Electric Safety

- Use this device only with a compatible and stable power supply, ensuring voltage fluctuations are less than 5%.
- Ensure the device is properly grounded before turning on the power.
- Keep the area around the laser engraver dry, well-ventilated, and maintain an ambient temperature between 10°~ 28°. The ambient humidity should not exceed 70%

### **Notes:**

***The machine operates best at 10-28 °C, temperatures outside this range may cause the laser to stop working.***

# Product Structure

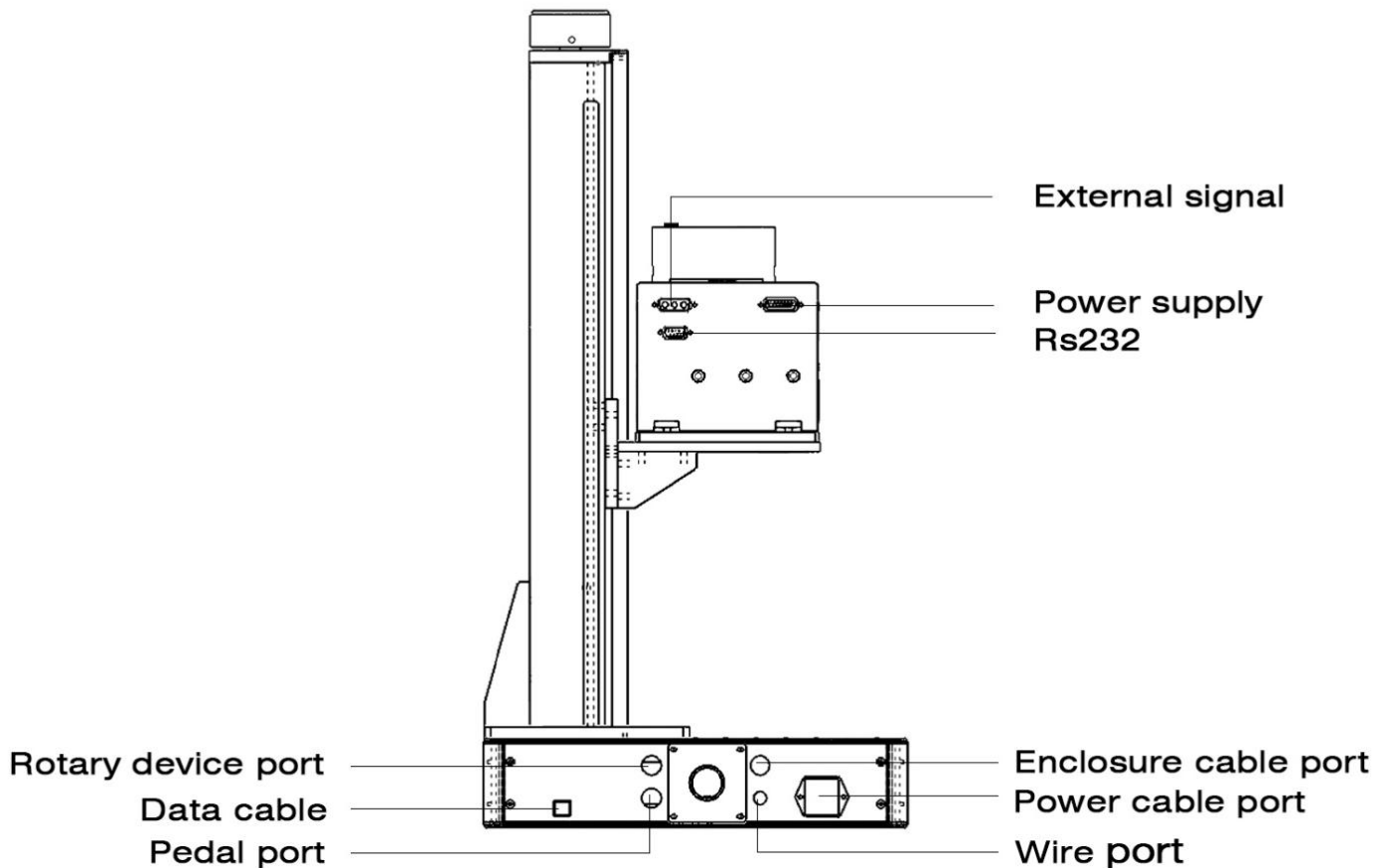
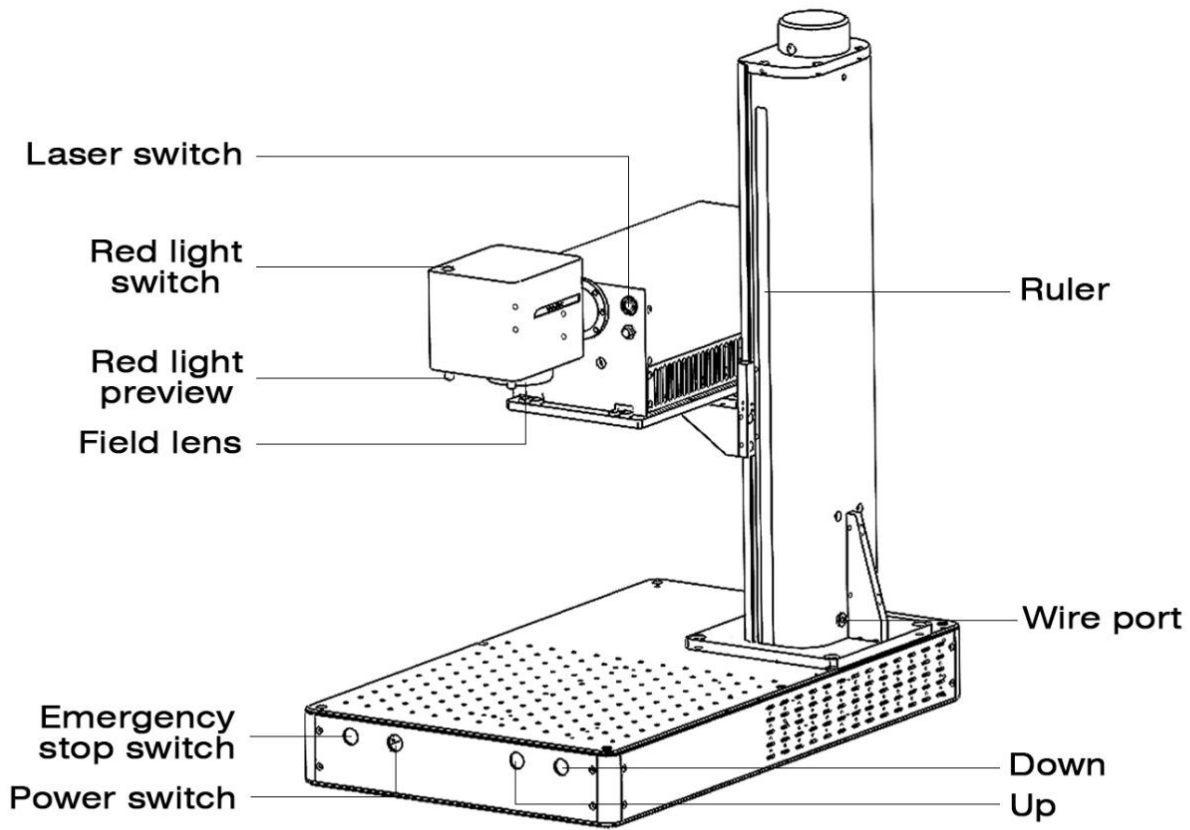

# List of items



Omni 1 Laser Engraver



Packing Box



Power Adaptor



Data Cable



Wire Cable

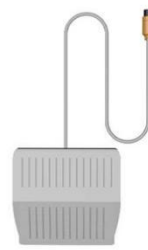

Foot Switch



Ruler



Field lens



OTG Adapter



USB Drive



Placing Helper



Allen Wrench



Goggles



Preview Helper



Lifting Platform



Screw M5

# Parameters

<b>Product Name</b>		Omni 1
<b>Voltage</b>		110-120V 60Hz
<b>Field Lens Specification</b>		70*70mm /150*150mm
<b>Marking Accuracy</b>		0.001mm
<b>Max. Marking Speed</b>		0-10000 mm/s
<b>Laser</b>	<b>Rated Power</b>	5W
	<b>Wavelength</b>	355nm
	<b>Expected Service Life</b>	10,000 hr.
	<b>Laser Type</b>	UV
<b>Cooling Type</b>		Air Cooling
<b>Dimension(L*W*H)</b>		35 x 65 x 72cm
<b>Weight (KG)</b>		23kgs
<b>Required Operating Environment</b>	<b>Max. Humidity</b>	<70%RH(Operating outside the recommended humidity range may reduce the laser's lifespan, degrade performance, or even cause damage)
	<b>Temp. Range</b>	32–82.4°F(0 - 28°C)
<b>Provided Operating Software</b>		EZCad
<b>Applicable Computer System</b>	<b>EZCad</b>	Windows 7/8/10/11
	<b>Lightburn (not Included)</b>	Windows 7/8/10/11, MacOS
<b>Applicable Image Formats</b>		BMP,GIF,JPG,JPEG,PNG,DXF,AI,SVG,etc.

# Assembly of Machine

1. Place the parts on the table.



2. Fasten the supporting pole with four screws.



3. Fix the laser head on the shelf



4. Connect the external signal and

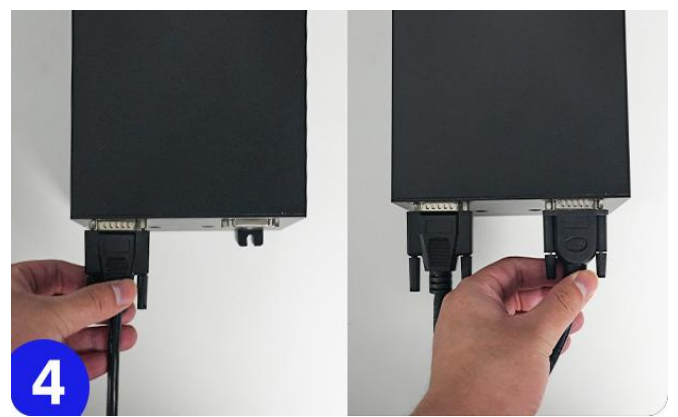

5. Connect the cable of galvanometer



6. Connect the wire cable on the case



7. Connect the wire on the supporting pole



8. Connect the data cable with the computer

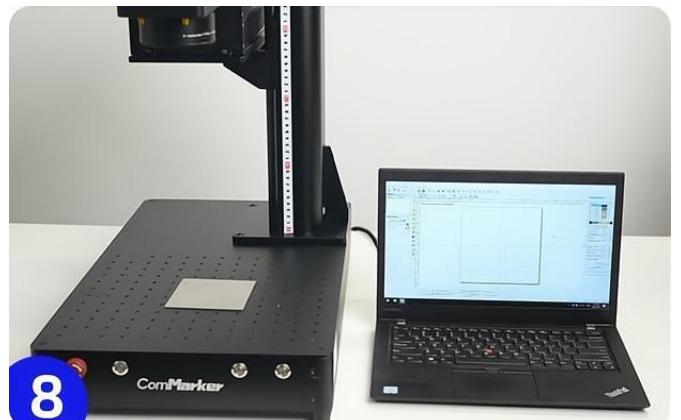



## Turn on the laser

Connect the Power cable and switch on the power, the laser's switch indicator light will alternately **flash blue and green**. After waiting for about 1-2 minutes, the indicator will turn **solid green**, indicating that the laser is ready and can start working

**Note:** *Ensure the laser switch button is on*





# Operation Instructions

## 1. Install the driver

Notes: \*It is recommended to copy and paste the files of the U disk to the computer desktop or other computer disks.

1.Right-click "this PC", click "Manage"

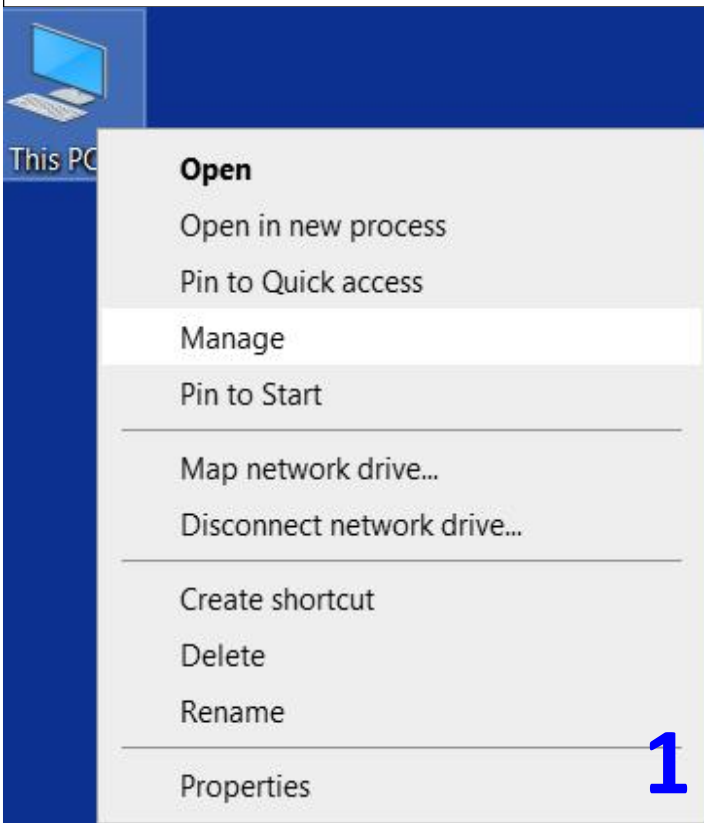

2.Click "Device Manager", find "USBLMVC2" in Other devices

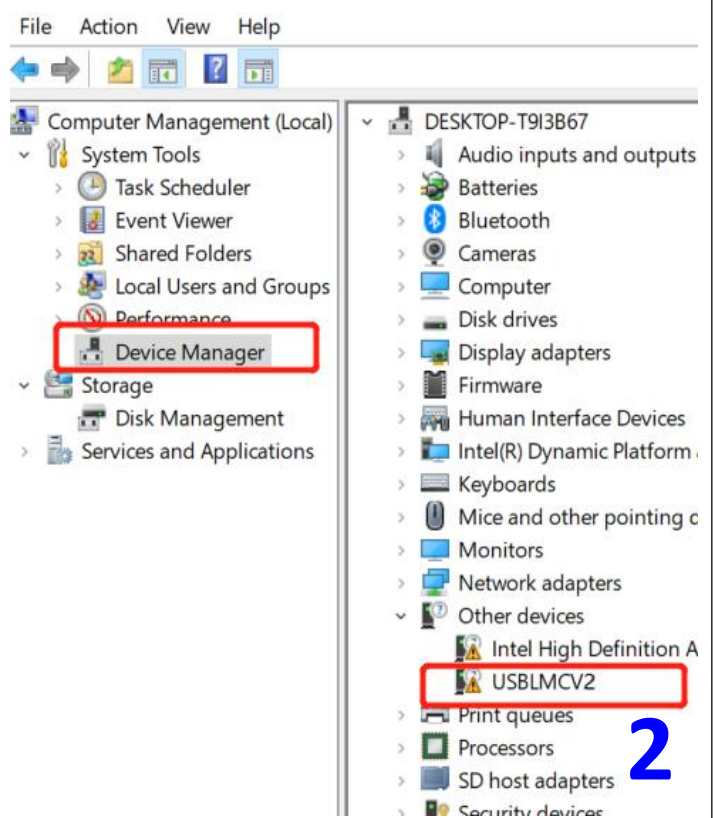

3.Right-click"USBLMVC4" and "Update driver"

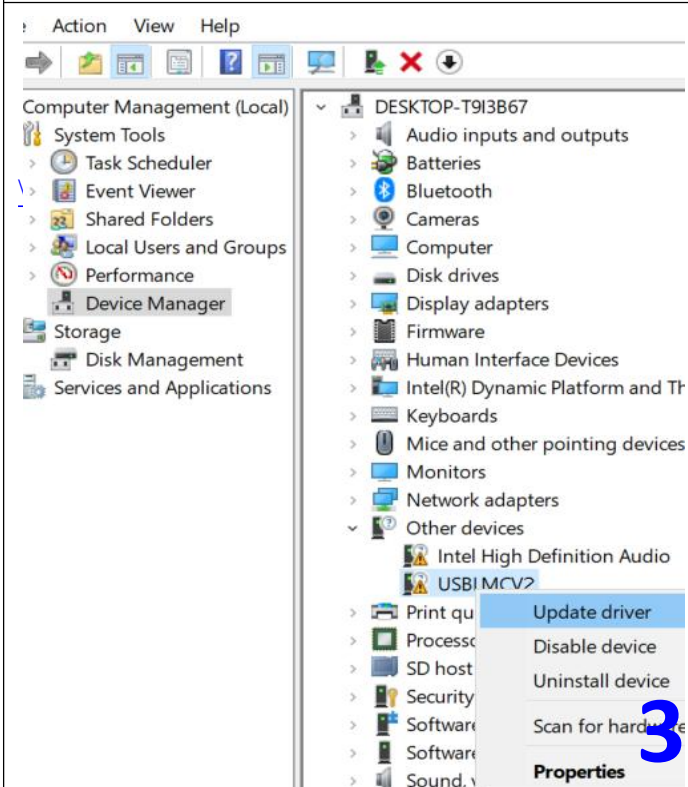

4.Select "Browse My Computer for Drivers"

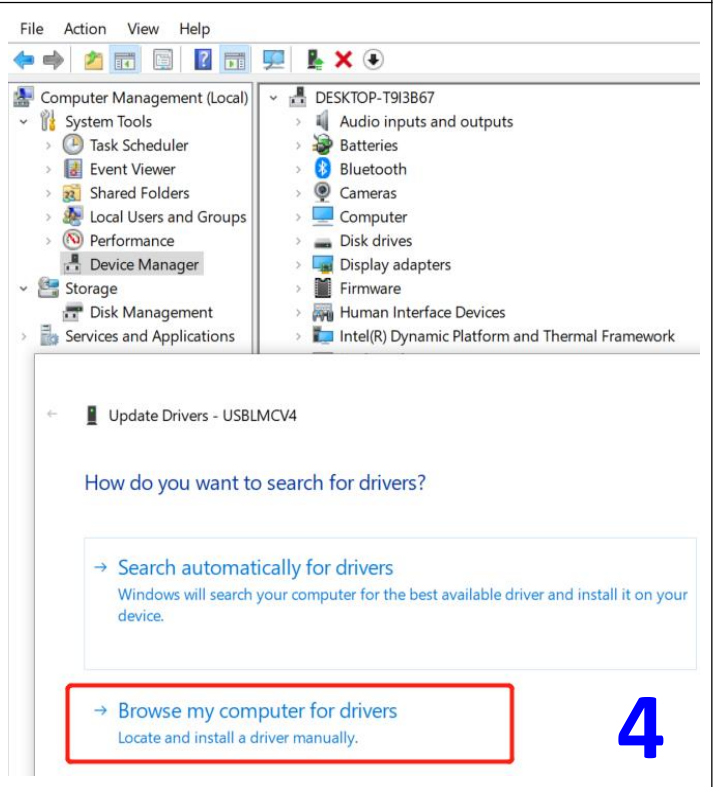

5. Find the corresponding file in the USB drive, click "OK"

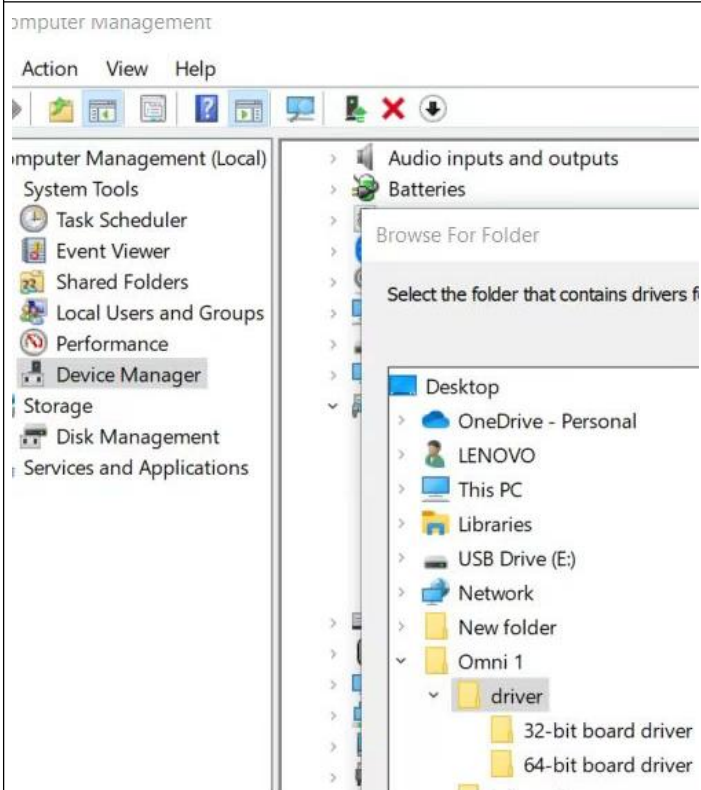

6. Click "Install"

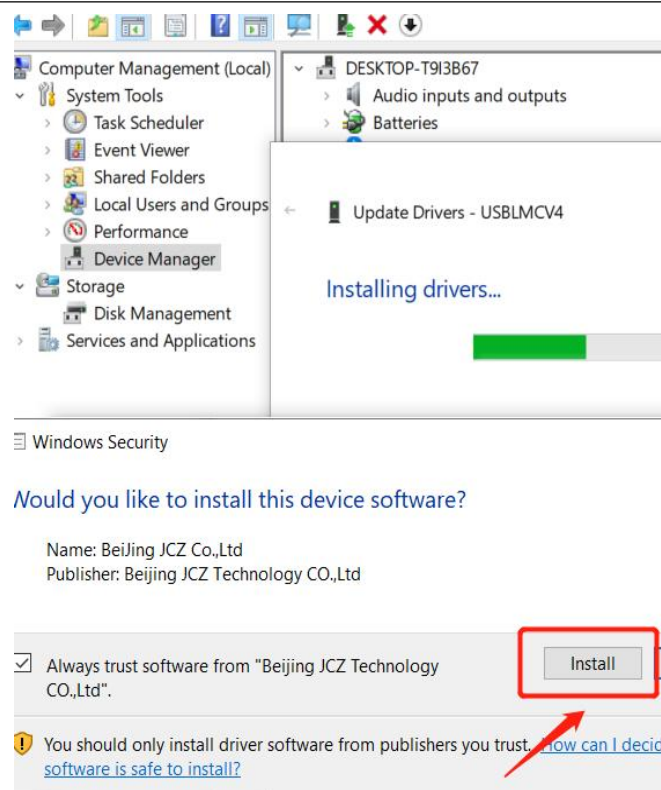

7. Click "finish" if it is successful

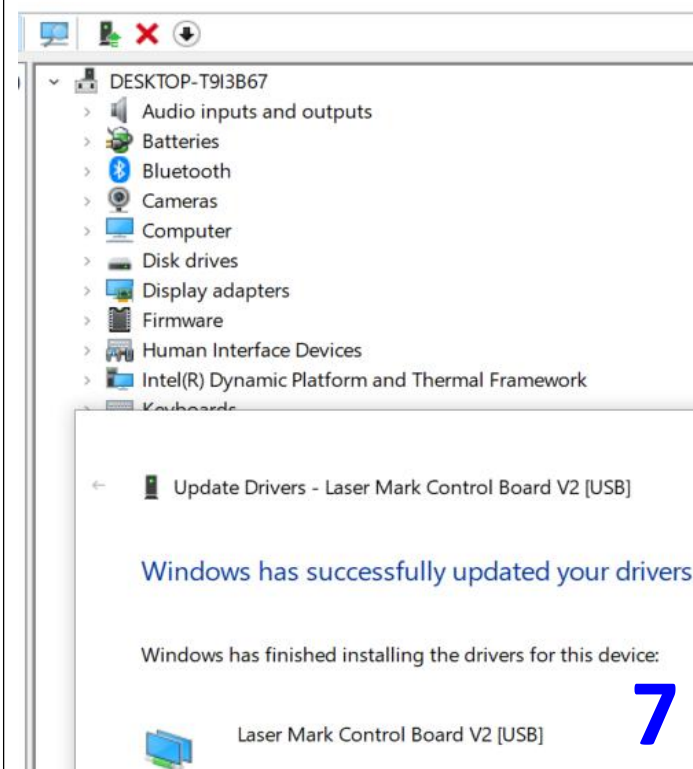

8. it will display "BJCZ Device" in Device Manager

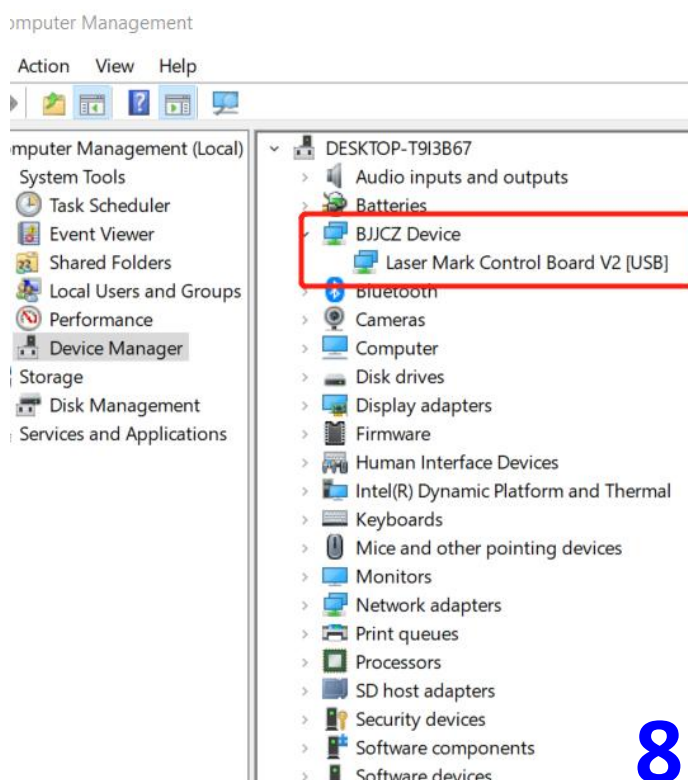

**Noted: If the driver installation is unsuccessful, please refer to FAQ 1.**

## 2. Open the software

Open the USB folder omni 1; open the "software15" folder. Open the software "EZCAD2". You can enter "text", "picture" or "vector diagram" as shown in the figure below. It is recommended to select the text to test first.

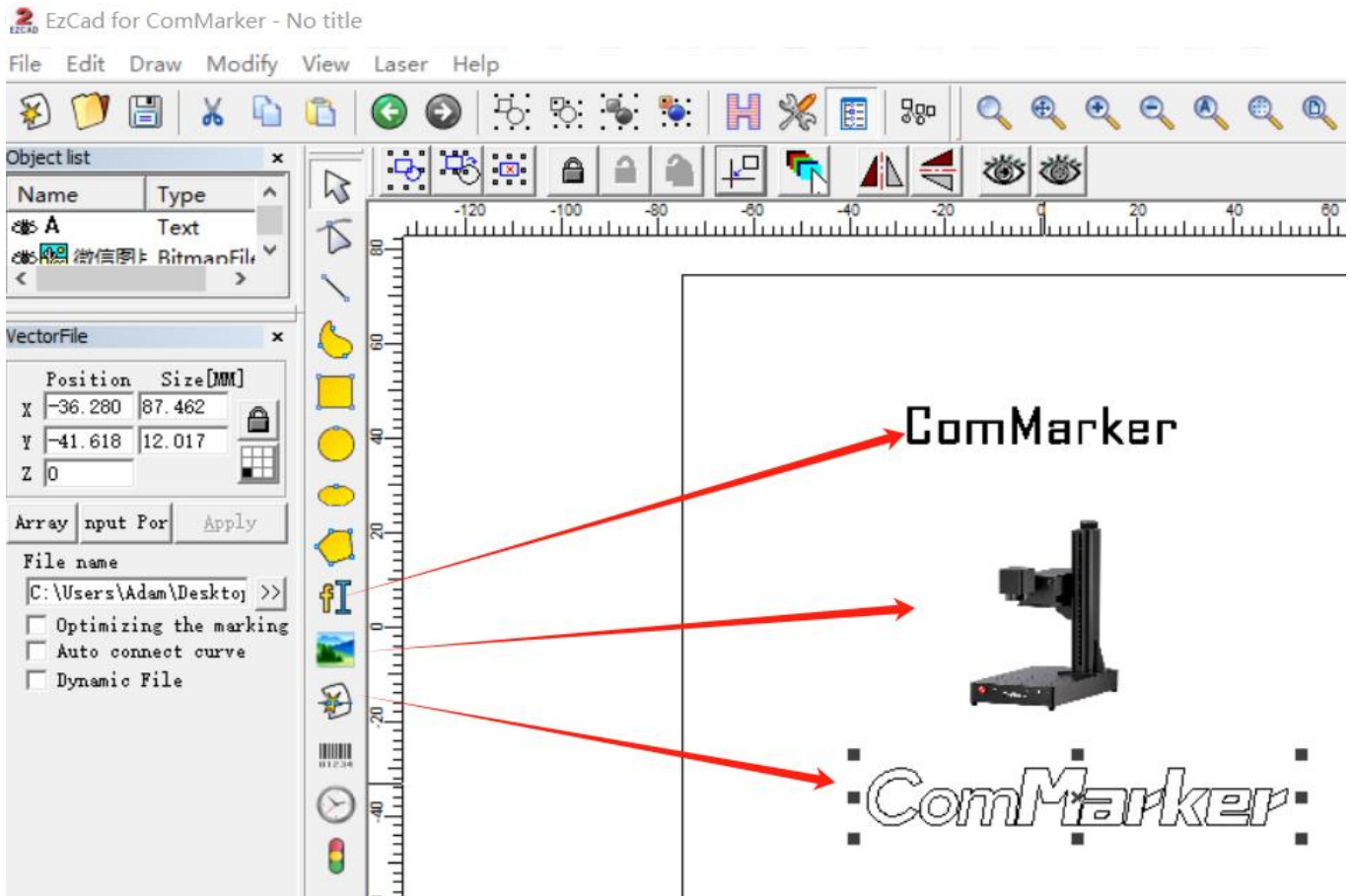

Select "Parameter (F3)", tick "Use Correct File", click , select the file ending in .cor in the USB flash drive (or have been copied to the computer disk), and click "OK".

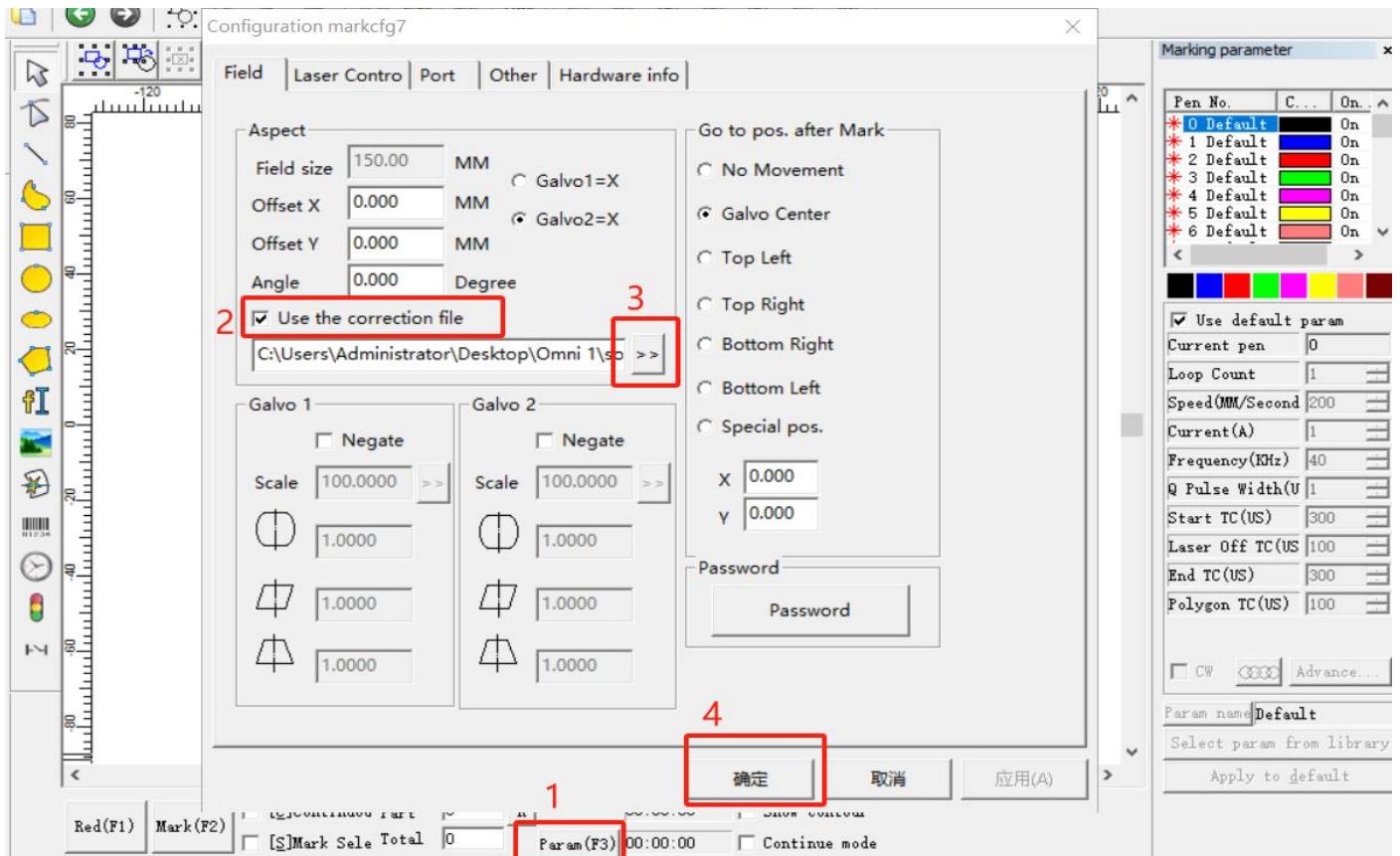



#### 4. Adjust the focus

Press up or down button to lift or lower the laser head until the 2 red light point overlap, which is the best focal point.

The measuring focal length of this machine is \_\_\_\_\_ mm (70x70) and \_\_\_\_\_ mm (150x150), and the measuring distance is the length from the middle line of the Galvo to the surface of the engraving material. This parameter is measured manually, and each device has different focal lengths due to changes in laser sources and field lenses.

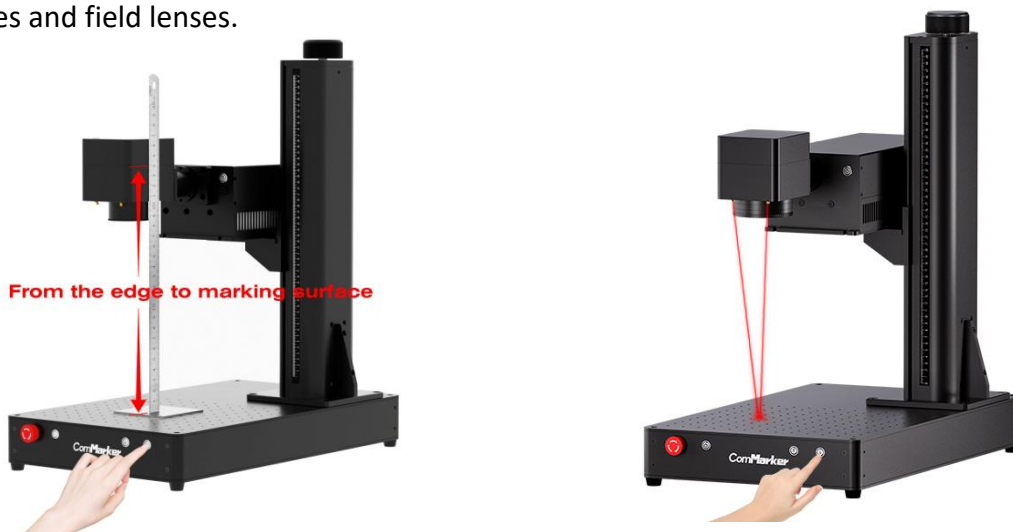

#### Note:

*\*The overlapping point should be on the marking material other than the surface of the machine.*

*\*Red light correction before shipping. At the position where the 2 red light spots are focused, the laser emits the strongest light. However, due to transportation reasons, the focus point of the red lights you received may shift, and the focus point would not be the best focal length.*

*Please follow the steps for debugging.*

1. Place the stainless steel test plate on the machine table

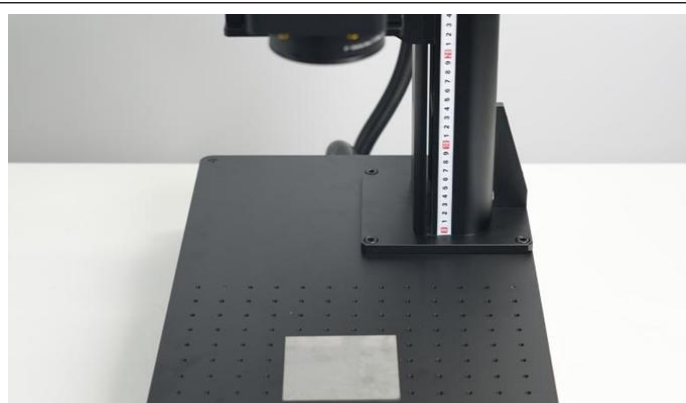

2. lift up or down the laser head to the best focus point according to the number in handwriting above

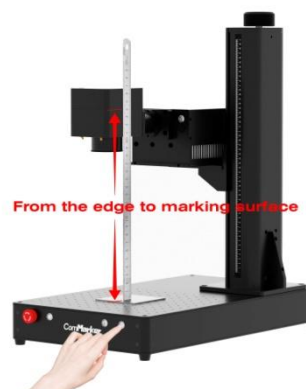

3. Turn on the machine, connect the computer with the machine

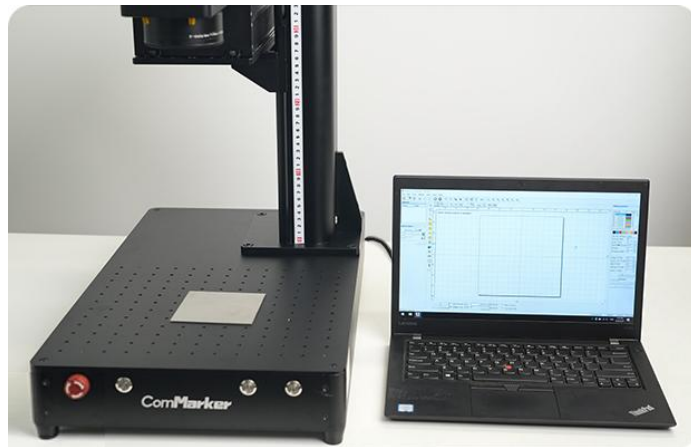

4. Import the "TEXT" for testing, select the default parameters, and tick the "continuous part" button.

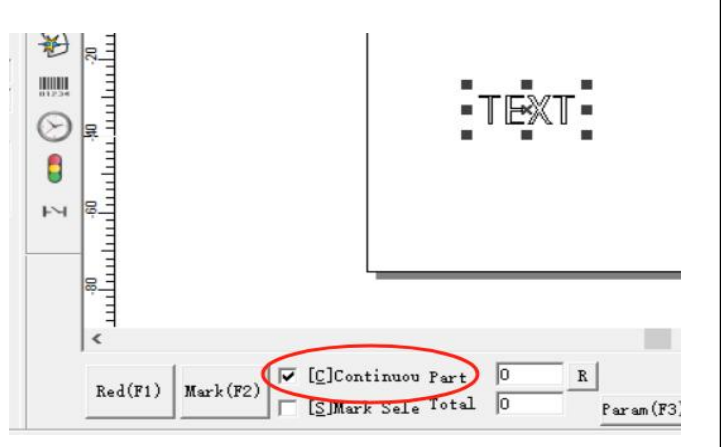

5. Press "red light" to ensure it'll mark on the test material. Click "mark", and the laser would be continuously marking

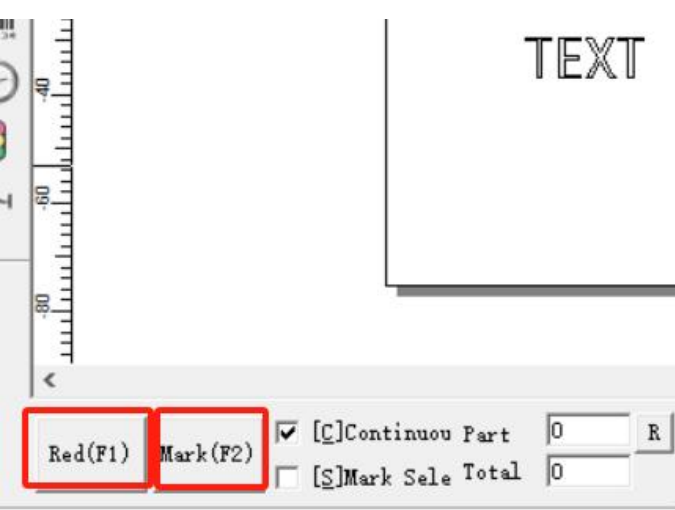

6. Meanwhile, lift or lower the laser head and observe the obvious change of intensity of the laser beam. Stop when the it works with the strongest laser



7. At this time, loosen the screws for the two beams of the auxiliary red light

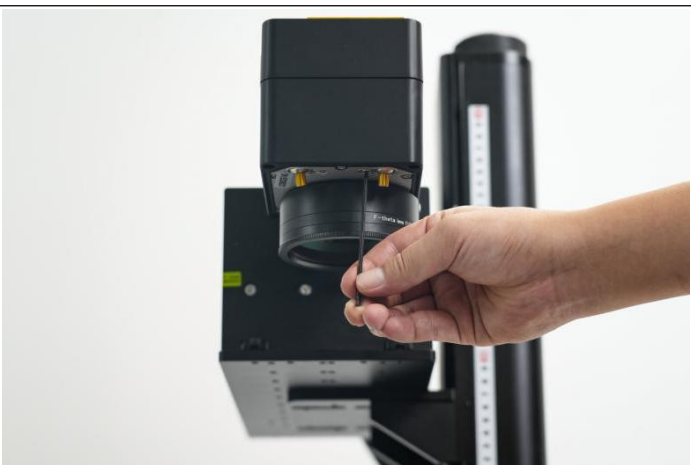

8. Manually adjust the relative position of the red light dots to make them overlap. And tighten the screws

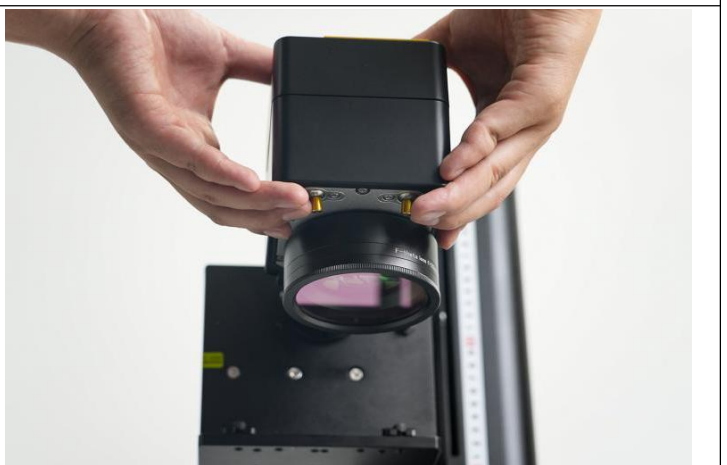

## 5. Marking test

Place the test engraving material on the machine. Click "Red Light (F1)", the area shown by the red light is the marking area. Choose the parameters according to the following picture. Click "Mark (F2)" to start marking.

Note: "Speed", "Frequency" and "Q Pulse Width" are key parameters for marking result.

The screenshot displays the ComMarker software interface. The central workspace shows a 3D model of a laser marking machine and the text "ComMarker" in a stylized font. The right-hand panel contains various settings, with several key parameters highlighted by red boxes:

- Speed(MM/Second): 200
- Frequency(KHz): 40
- Q Pulse Width(V): 1
- Start TC(US): 300

The bottom status bar includes control buttons for "Red(F1)" and "Mark(F2)", along with checkboxes for "Continuou Part" and "Mark Sele Total", and numerical input fields for "R" and "Param(F3)".

# LightBurn Operation Tutorial (For MacOS)

## Download and install Lightburn software from the website

Note: It is not compatible with our machine if your Lightburn version is lower than V1.3.01, please download a new version and reinstall.

And Lightburn is a paid software with 1 month free trial, you need to buy the licence key for Galvo version.

1. Down load the software from the website:  
<https://lightburnsoftware.com/pages/download-trial>

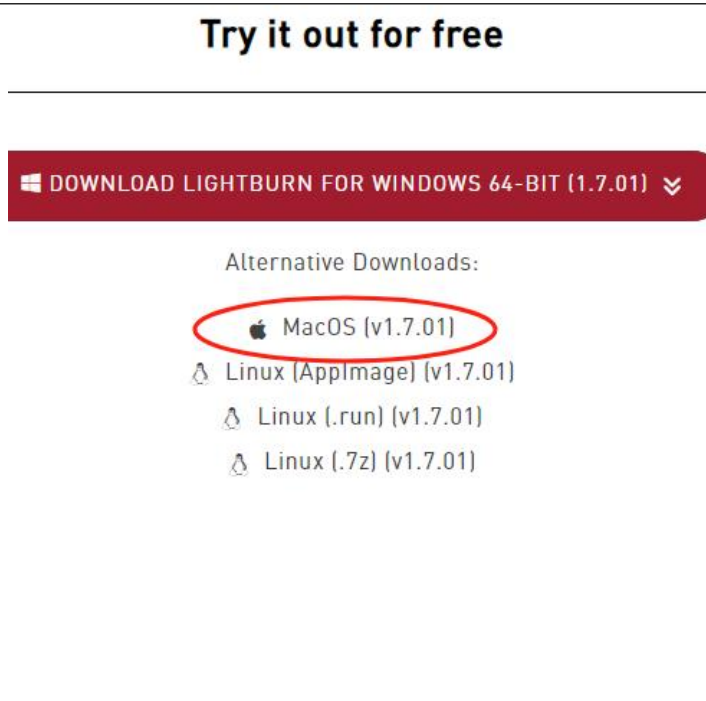

2.Find downloaded file Lightburn V1.7.01, and drag Lightburn icon to the Applications folder

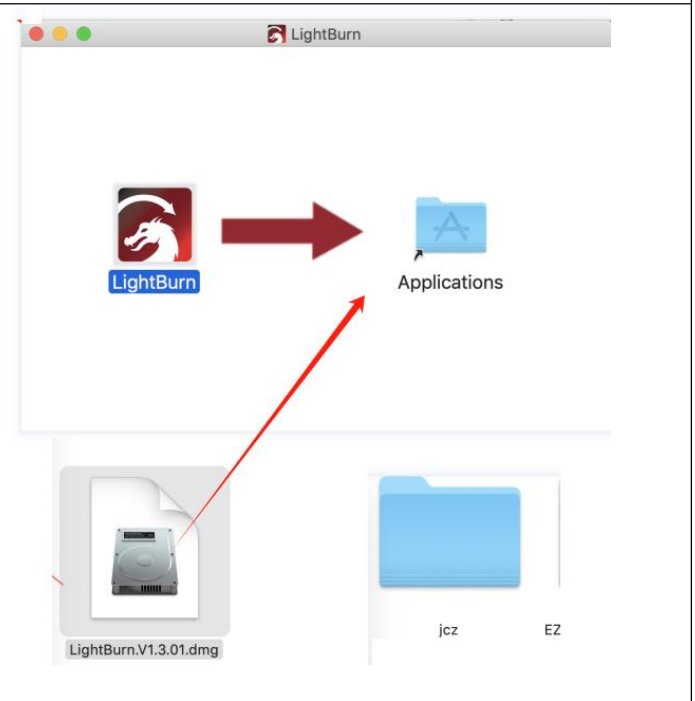

3.Copy the folder “Omni 1” from the USB to the desktop

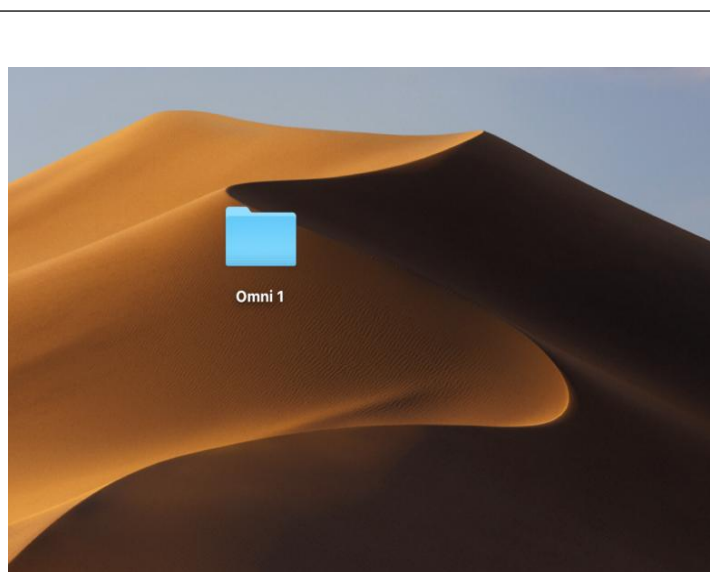

4. A device window will pop out if the software is open the first time, click “Create Manually”, Select “JCZFiber”

**Note: Make sure the machine is on and connected**

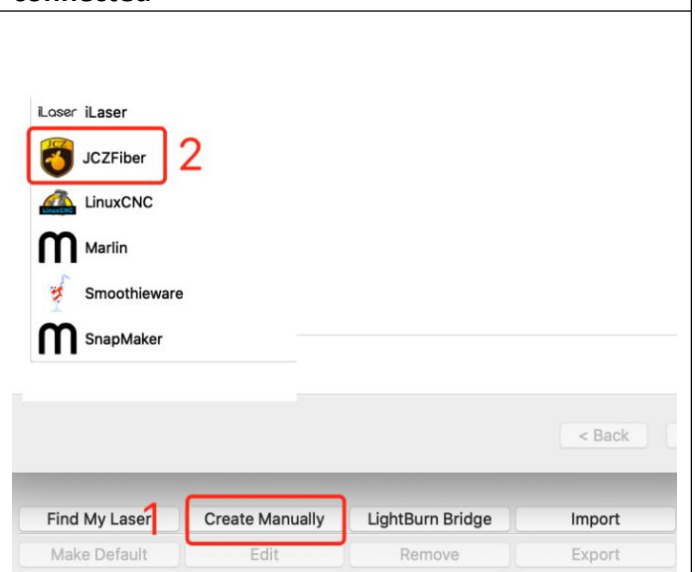



5.Import EZCAD Config and select the folder

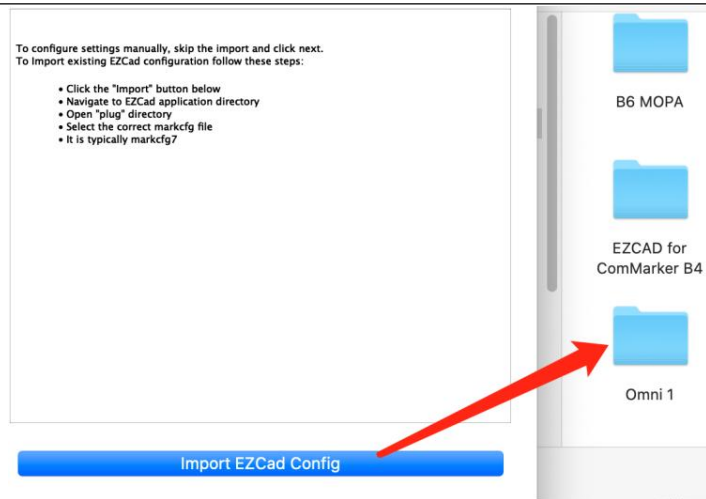

6.Select folder “EZCAD for Omni 1”---->“ Plug”, and choose “markcfg7” and click “next”

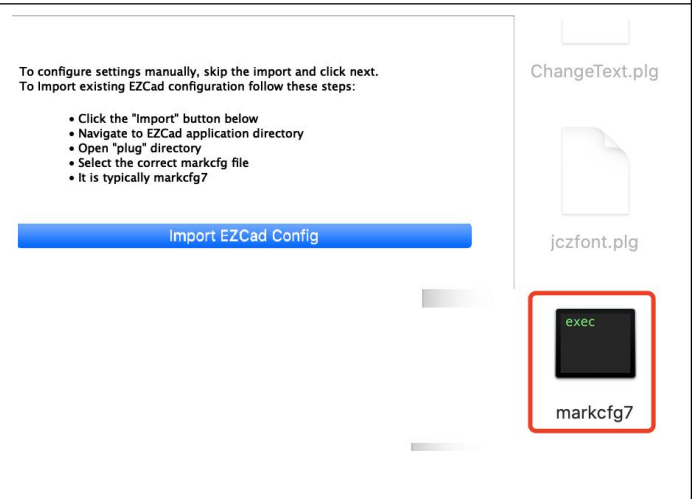

7.You can see the following window, UV/YAG and click “next”

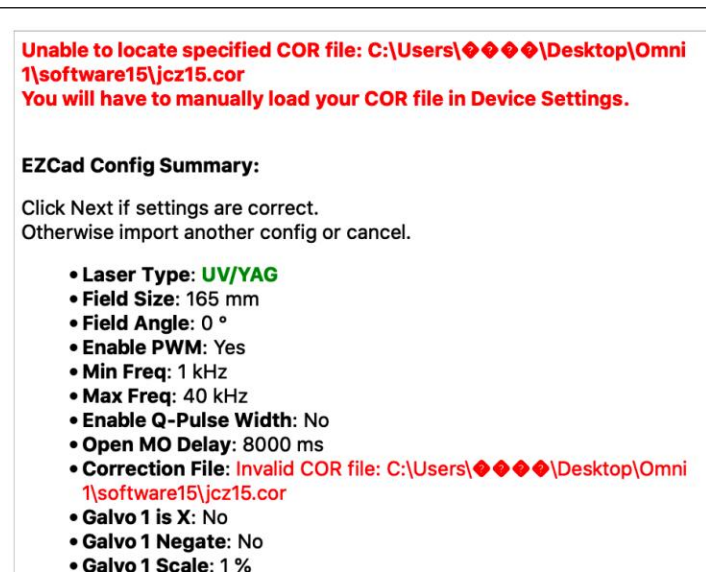

8. Change the name if necessary, and input the right X and Y Axis Length according to the lens. Click “next”

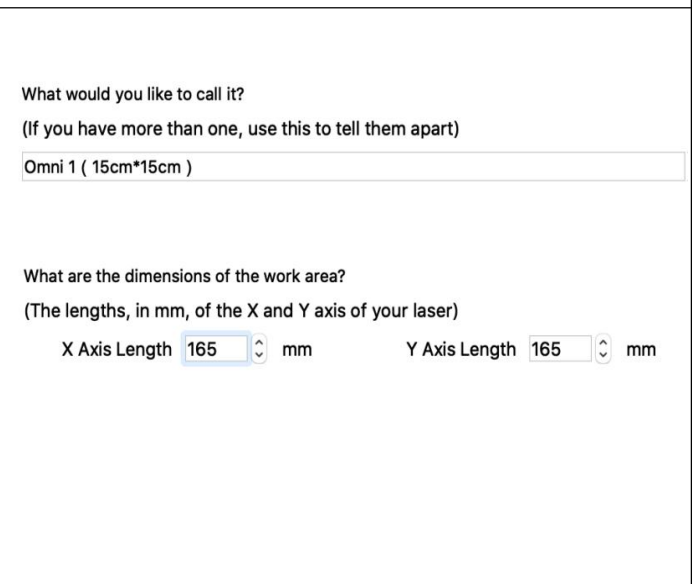

9.Click “finish” and it will in the device list

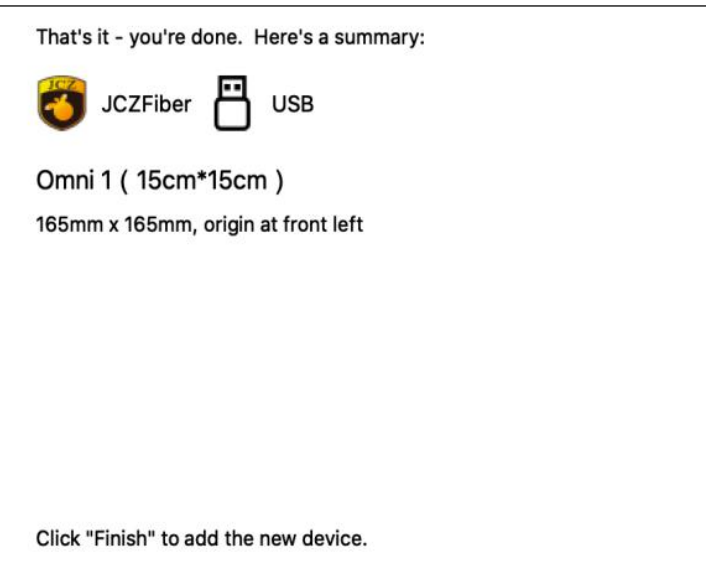

10. The status will change into “Ready” when the machine is on and connected via USB

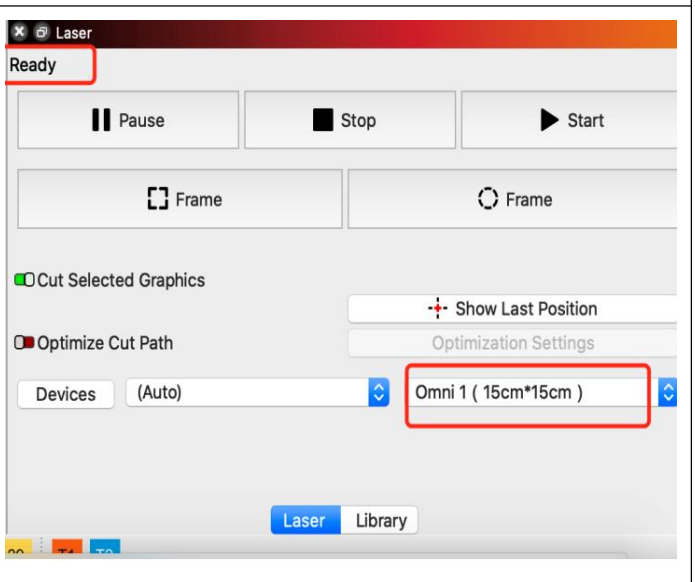

11. Go to “Basic Settings” from “Device setting” button, click “Load COR file”, Select “omni 1”, Choose file “JCZ15.cor”, Click “OK”

12. Change the setting of Freq “Min 1”, “Max 40”. Switch on “Galvo 2”. Set the Laser Type UV, and it is ready to control the machine with Lightburn.

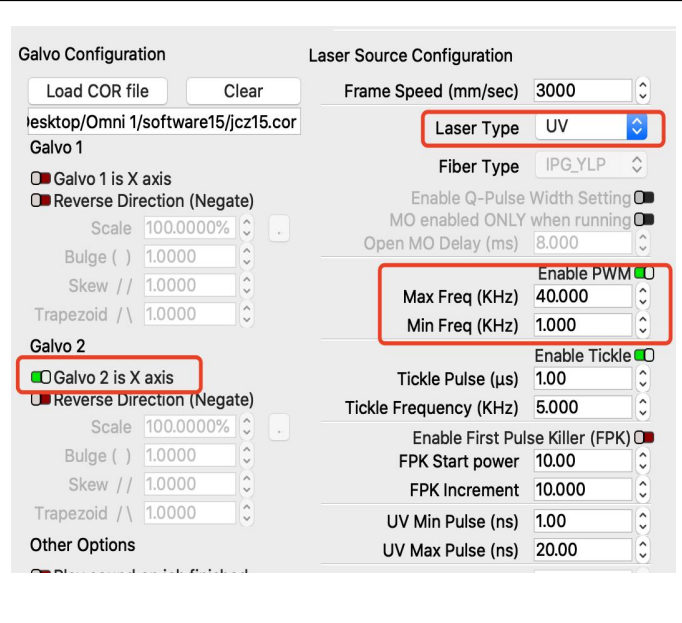
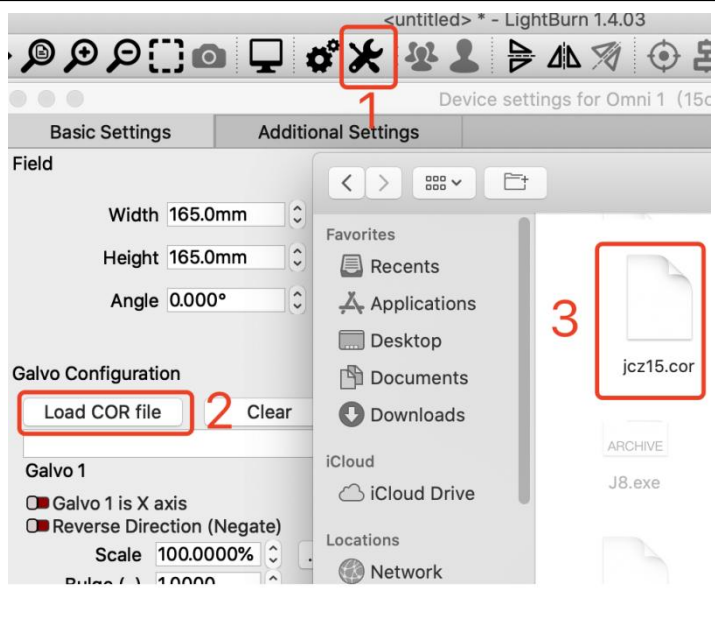

# FAQ

## Q1: The driver installation was unsuccessful?

- \*Please make sure to use the copyrighted window system, if not, please replace it with another computer
- \*Please try to replace a data cable, it is recommended to use a magnetic proof cable
- \*It may be a computer port problem or a computer board connection problem, please try with another computer

## Q2: The USB flash drive is damaged and cannot be opened

- \*Please visit Commarker's official website to download the omni driver and software.
- \*Contact after-sales staff or email us

## Q3: The red light preview functions, but there is no mark or the marks are very light

- \*Please adjust the focal length; please refer to question 2 for debugging methods
- \*Contact after sales staff or email us

## Q4: Can not find dongle, software will work at demo state

- \*The machine is not powered on, or the machine is not connected to the computer. Please turn it on and make sure the data cable is connected to the computer

## Q5. The size of preview and the mark is inconsistent with the software display, or preview and the mark are not horizontal or vertical but with angles.

- \*Import the calibration file, please refer to step 3 of the operating instructions
- \*If the problem not solved, select "Parameter (F3)", select "Field". Input numbers in "Offset X", "Offset Y" or "Angle" according to the actual deviation number based on the measurement with a ruler.
- \*If it still doesn't work, please contact after-sales staff or email us

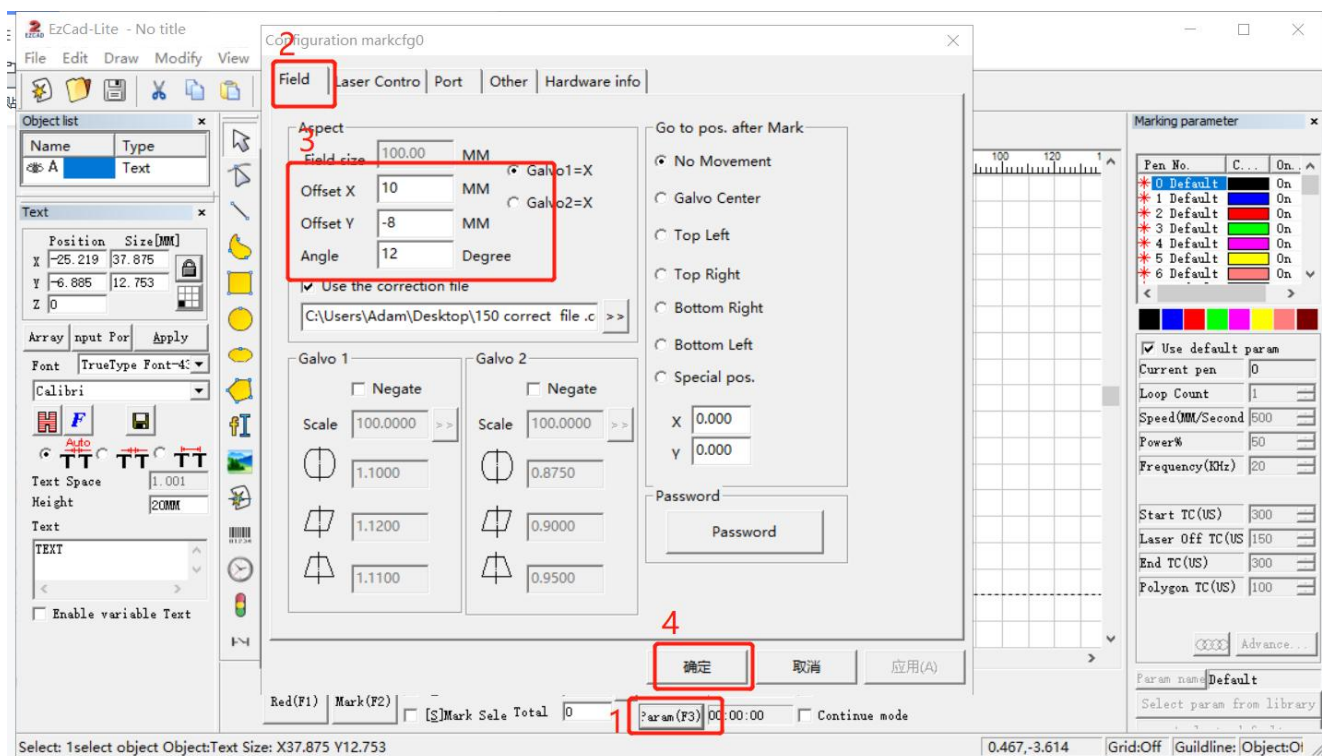

## Q6: The red light preview is inconsistent with the actual engraving position

- \*Import the calibration file, please refer to step 3 of the operating instructions
- \*If the problem not solved, select "Parameter (F3)", select "Other" and "Red light pointer". Input numbers in "Offset X" and "Offset Y" according to the actual deviation number based on the measurement with a ruler. The number can be positive or negative, the red light will change in different directions at the positive and negative values.

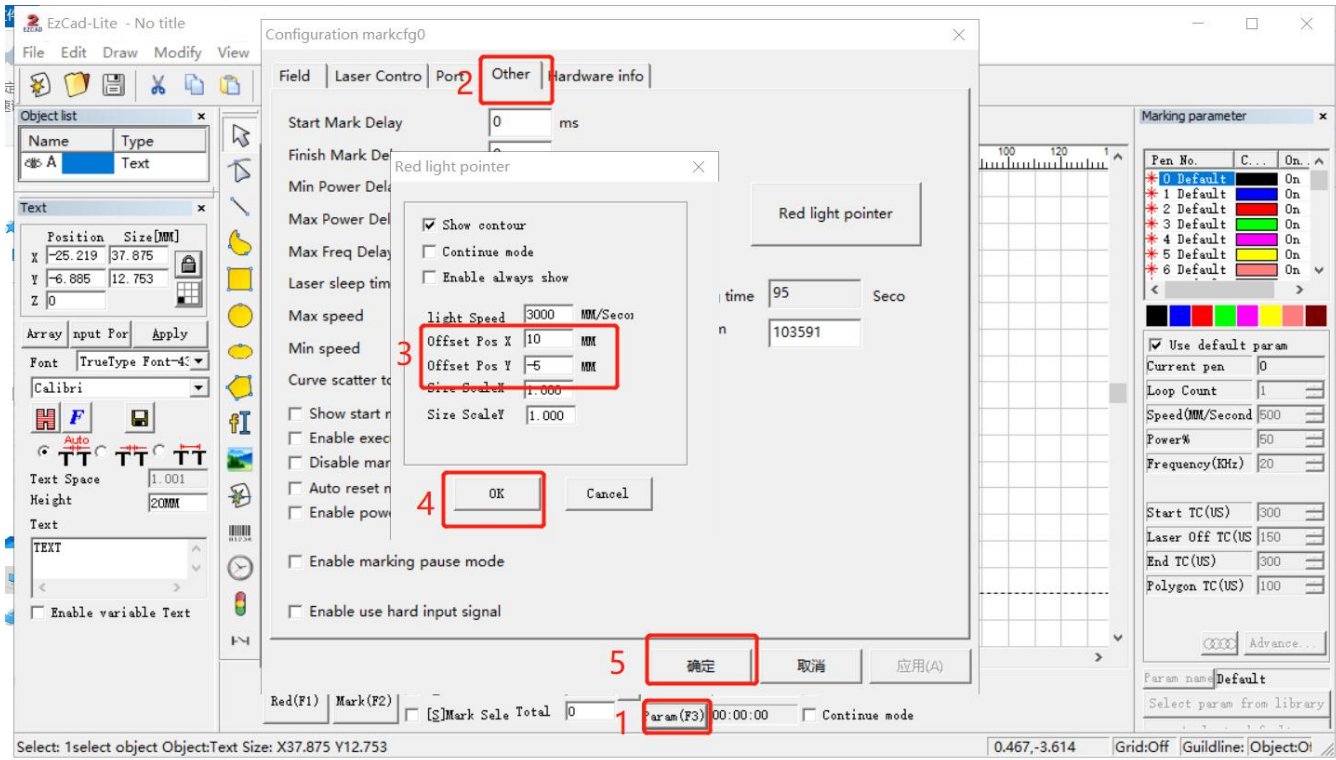

**Q7: The preview and the shape of the mark is deformed**

- \*Import the calibration file, please refer to step 3 of the operating instructions
- \*If it still doesn't work, please contact after-sales staff or email us

**Q8: Nothing displays on canvas board when importing text or picture**

- \*Please click the practical center button, the picture and text are in the center of the canvas

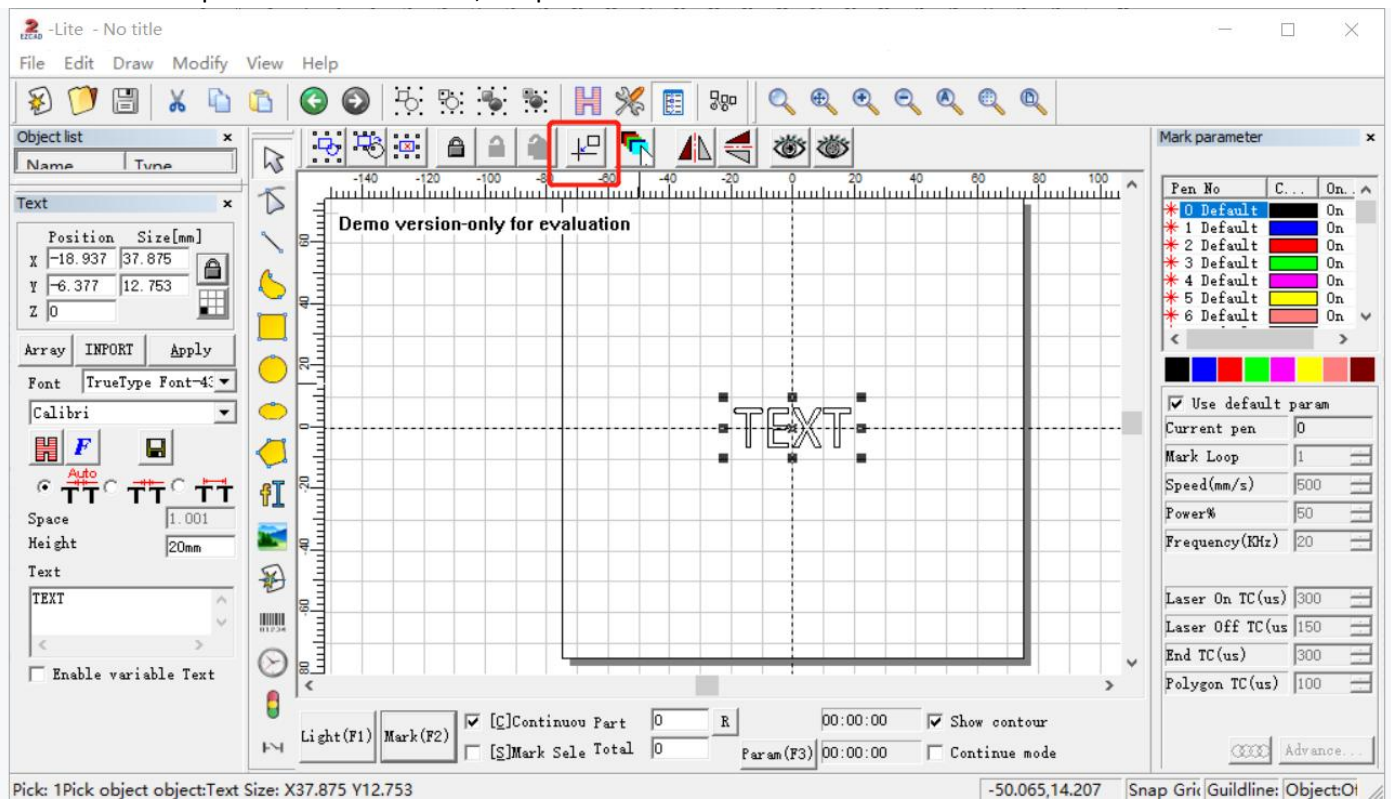

**Note: This manual will be continuously updated. Please download the latest e-version manual on our website.**

# Maintenance

## 1. Maintenance Overview



Unless otherwise specified, perform adjustment and maintenance of this device only when the power is turned off and the power supply has been disconnected. Only trained and skilled professionals should modify or disassemble this device.

## 2. Regular Maintenance Procedures

- Keep the workroom clean and dust-free at all times.
- Ensure the device is fully powered off when not in use.
- Cover the galvanometric lens when it is not in use.
- Clean the worktable after use with a cloth wetted with more than 75% rubbing alcohol.
- **Never** clean this device with abrasive or caustic cleansers, aerosol sprays, or enough water to enter any electrical component. Always allow surfaces to fully dry before further use.
- When removing dust from the device's vents using a vacuum, **ONLY** use the lowest power setting to avoid damage to internal components.

 No other servicing should be done by the operator. Do not attempt to service or replace other parts yourself.

## 3. Troubleshooting Guidance

Potential Problems	Possible Solutions
No Laser Output	Correct the focus by adjusting the height of the laser arm.
	Correct the software parameters if they are invalid or mistaken.
	Have a technician fix or establish the connection between the laser and the mainboard.
	Have a technician fix or establish the connection between the laser and its power supply.
	If either the fiber laser source or its power supply has worn out, have a technician replace them.
No Engraving despite Laser Output	Confirm that the material can be safely engraved with this device.
	Correct the focus by adjusting the height of the laser arm.
	Adjust the software parameters to create greater intensity.
	Have a technician check the control panel, scanning lens, and their power supply. Correct any problems or replace the parts.
Other Laser Errors	Have a technician check the fiber.
	Have a technician check the fiber laser source and the mainboard. Correct any problems or replace the parts.



# ComMarker

## **Customer Service:**

- For more video and supportive materials, please visit our official website at:  
[www.commarker.com](http://www.commarker.com)
- For Laser Engraver technical support and service please email:  
[support@commarker.com](mailto:support@commarker.com)

**Manufacturer: ComMarker Industrial Co., Limited**